

# BIG BIKE PARTS® INSTALLATION INSTRUCTIONS

Copyright© 2006 by Big Bike Parts, Inc.  
No part of this instruction sheet may be reproduced without the written permission of Big Bike Parts, Inc.

WINDSHIELD FRESH AIR VENT  
NO. 2-359C & NO. 2-511

FOR HONDA GL1500/6  
GOLD WING MODELS

Revised 8/22/13

## IMPORTANT NOTICE: READ BEFORE ATTEMPTING INSTALLATION

### DISCLAIMER

CAUTION: CUTTING AND/OR DRILLING HOLES INTO POLYCARBONATE WINDSHIELD MATERIAL MAY CAUSE CRACKING AND/OR SCRATCH DAMAGE TO THE WINDSHIELD. THEREFORE, WE RECOMMEND INSTALLATION OF THE FRESH AIR VENT IS MADE BY A PROFESSIONAL GLASS SERVICE SHOP. SHOULD THE OWNER OF THIS DEVICE DESIRE TO ATTEMPT A DO-IT-YOURSELF INSTALLATION, OR HAVE THE INSTALLATION MADE BY A MOTORCYCLE SERVICE DEPARTMENT, THE FOLLOWING DETAILED INSTRUCTIONS MUST BE FOLLOWED.

THE BELOW INSTRUCTIONS ARE PROVIDED AS A GUIDE TO ELIMINATING POSSIBLE WINDSHIELD DAMAGE WHEN INSTALLATION IS ATTEMPTED BY THE OWNER OR MOTORCYCLE SERVICE DEPARTMENT. IN ANY EVENT, BIG BIKE PARTS, INC. WILL NOT BE LIABLE OR RESPONSIBLE FOR ANY WINDSHIELD DAMAGE. OUR WARRANTY APPLIES ONLY TO OUR PART.

#### ITEMS REQUIRED:

#1 SMALL PHILLIPS SCREWDRIVER  
CLOTH DUCT TAPE  
HAMMER  
CENTER PUNCH  
7/16" DIAMETER DRILL BIT

#2 MEDIUM PHILLIPS SCREWDRIVER  
SOFT CLEAN CLOTH  
RAINTUS BLUE LOW STICK MASKING TAPE  
12" LONG 2" X 4" WOOD BLOCK  
SABER SAW OR HACK SAW BLADE

VARIABLE SPEED ELECTRIC DRILL  
UTILITY KNIFE  
FLAT FILE OR SAND PAPER  
ROUND FILE

1. UNHOOK THE L/R RUBBER MIRROR GASKETS (1A) FROM THE MIRRORS (1B) AND MIRROR COVERS (1C).
2. RELEASE THE L/R MIRROR COVER SPRING CLAMPS (2A) FROM THE FAIRING LEDGE (2B) AND PIVOT THE MIRROR COVERS (2C) SO AS TO EXPOSE SCREWS (3A & 4A) HOLDING THE TRIM HOLDER (3B) AND WINDSHIELD PANEL (4B).
3. PIVOT THE MIRRORS (1B) BACK AND OUT OF THE WAY. USING #2 MEDIUM PHILLIPS SCREWDRIVER, REMOVE THE L/R SCREWS (3A) HOLDING THE TRIM HOLDER (3B).
4. GRASP THE TRIM HOLDER (3B) AND PULL IT FORWARD TO REMOVE FROM THE MOTORCYCLE.
5. USING A #2 MEDIUM PHILLIPS SCREWDRIVER, REMOVE THE L/R SCREWS (4A) HOLDING THE WINDSHIELD PANEL.
6. GRASP THE WINDSHIELD PANEL (4B) AND PULL IT FORWARD TO DISENGAGE THE TWO TABS (4C) JUST ABOVE THE HEADLIGHT (4D).
7. USING A #2 MEDIUM PHILLIPS SCREWDRIVER, REMOVE THE FIVE SCREWS (5A) HOLDING THE WINDSHIELD (5B).
8. REMOVE THE WINDSHIELD (5B) AND COVER THE INSIDE SURFACE OF THE WINDSHIELD IN THE AREA TO BE CUT-OUT WITH CLOTH DUCT TAPE. TAPE A LARGE ENOUGH AREA AROUND THE CUT-OUT AREA TO PROTECT THE REMAINING ADJACENT WINDSHIELD AREA. PLACE THE WINDSHIELD ON A WORKBENCH, PROTECTING IT WITH A SOFT CLEAN CLOTH.
9. ATTACH THE INCLUDED PAPER TEMPLATE (6A) TO THE OUTSIDE OF THE WINDSHIELD (6B), USING MASKING TAPE (6C) ON ALL FOUR SIDES. DO NOT LEAVE ON FOR AN EXTENDED PERIOD.
10. USING A HAMMER AND CENTER PUNCH, TRANSFER THE HOLE CENTERS (6D) OF THE TEMPLATE (6A) ONTO THE WINDSHIELD. SUPPORT THE UNDERSIDE OF THE WINDSHIELD UNDER EACH END OF THE TEMPLATE PRIOR TO HOLE TRANSFERS WITH A 12" LENGTH OF 2" X 4" WOOD BLOCK COVERED WITH A SOFT CLOTH.
11. USING A VERY SHARP UTILITY KNIFE, CAREFULLY SCRIBE THE FOUR SIDES OF THE CUT-OUT (6E) ONTO THE WINDSHIELD USING THE TEMPLATE (6A) ATTACHED. REMOVE THE TEMPLATE (6A) AND COVER THE OUTSIDE OF THE WINDSHIELD AROUND THE CUT-OUT AREA WITH CLOTH DUCT TAPE TO PROTECT THE ADJACENT WINDSHIELD AREA DURING CUTTING. DO NOT LEAVE TAPE ON FOR AN EXTENDED PERIOD.
12. USING AN ELECTRIC DRILL AND 7/16" DRILL BIT, AND APPLYING MODERATE SPEED AND LIGHT PRESSURE TO AVOID "GRABBING" WHEN THE BIT PENETRATES, DRILL CORNER HOLES (6F) WITH THE 2" X 4" WOOD BLOCK BENEATH THE WINDSHIELD FOR BACK UP.
13. USING A SABER SAW OR HACK SAW BLADE WITH A MINIMUM OF 24 TEETH PER INCH OR FINER, CAREFULLY AND PATIENTLY COMPLETE THE CUT OUT BY CUTTING ON THE SCRIBE LINES (6E). SUPPORT THE ADJACENT WINDSHIELD AREA WITH THE 2" X 4" WOOD BLOCK NEXT TO THE CUT-OUT.

14. USING A #1 SMALL PHILLIPS SCREWDRIVER, REMOVE THE TWO SCREWS (7A) HOLDING THE VENT TOGETHER. RELEASE THE SNAP TAP (7B) BY PUSHING UPWARDS AND REMOVE THE SMALL OUTSIDE COVER PLATE (7C). REMOVE BURR FROM INSIDE VENT WITH A UTILITY KNIFE. PLACE THE WINDSHIELD FACE DOWN WITH WOOD BLOCK AND CLOTH UNDER IT (FIGURE #8). PUTTING PRESSURE (LIGHTLY) DOWN ON BOTH SIDES OF WINDSHIELD WILL ALLOW BOTH PIECES TO BE INSERTED AND LINED UP TO INSTALL SCREWS. TRIAL FIT INTO THE WINDSHIELD CUT-OUT (7D). THE COVER PLATE SHOULD BE INSERTED TOP FIRST INTO THE CUT-OUT (7D) AND PIVOTED DOWNWARD TO ENGAGE THE SNAP TAB (7B) EASILY INTO PLACE WITHOUT BINDING. DO NOT FORCE THE COVER INTO PLACE, EXCEPT AT THE SNAP TAB (7B). IF NECESSARY, REMOVE THE COVER PLATE BY PUSHING UPWARDS ON THE SNAP TAB (7B) AND ENLARGE THE CUT-OUT (7D) WHERE NEEDED, USING A FLAT OR ROUND FILE OR SAND PAPER. **NOTE:** THE BALL BEARING ON THE LEVER OF THE VENT MAY NEED TO BE SPRAYED WITH SILICON FROM TIME TO TIME TO AVOID BINDING.
15. WHEN A SATISFACTORY FIT IS OBTAINED, REMOVE THE OUTSIDE COVER PLATE (7C) BY PUSHING UPWARDS ON THE SNAP TAB (7B), REMOVE ALL DUCT TAPE AND CLEAN WINDSHIELD USING MANUFACTURER'S CLEANING RECOMMENDATIONS.
16. REINSTALL THE OUTSIDE COVER PLATE (7C) INTO THE CUT-OUT (7D) OPENING, USING FIGURE #8. POSITION THE INSIDE OPERATING VENT (7G) AND USING A #1 SMALL PHILLIPS SCREWDRIVER, INSTALL THE TWO MOUNTING SCREWS (7A) SECURELY (DO NOT OVER TIGHTEN).
17. REPLACE WINDSHIELD (7F) AND ALL OTHER COMPONENTS BY REVERSING STEPS 1 THROUGH 7.

FIGURE #1

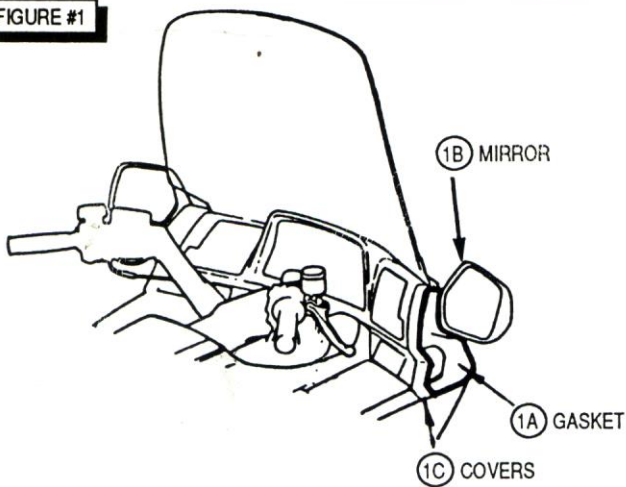

FIGURE #2

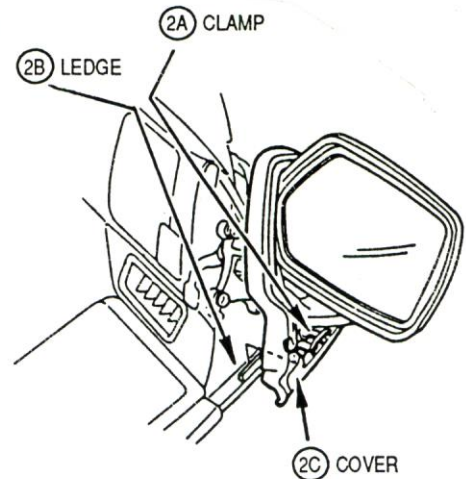

FIGURE #3

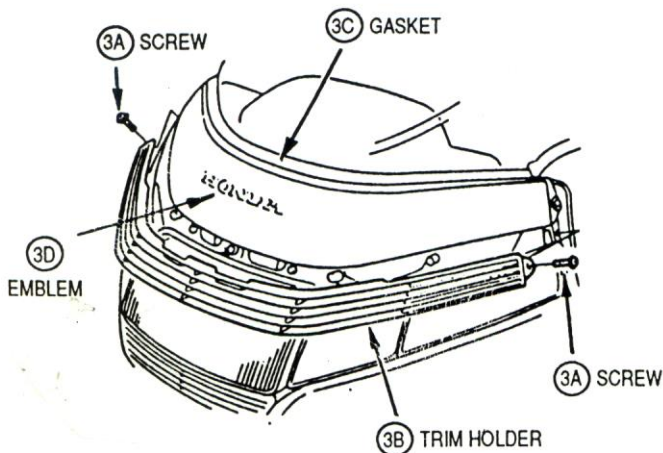

FIGURE #4

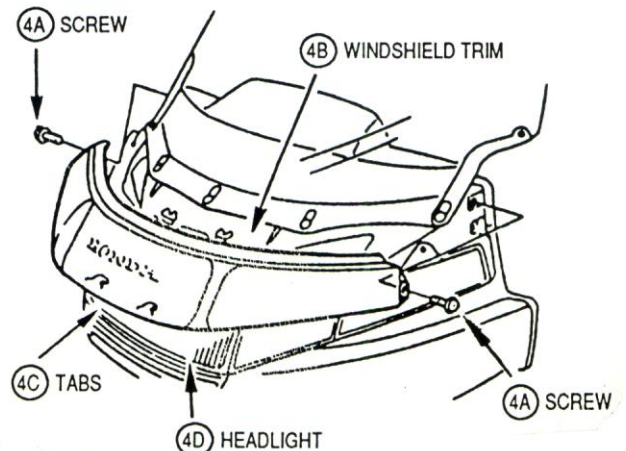

FIGURE #5

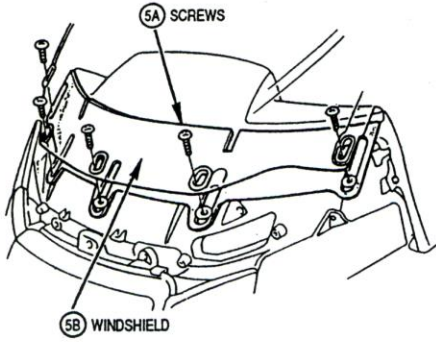

FIGURE #6

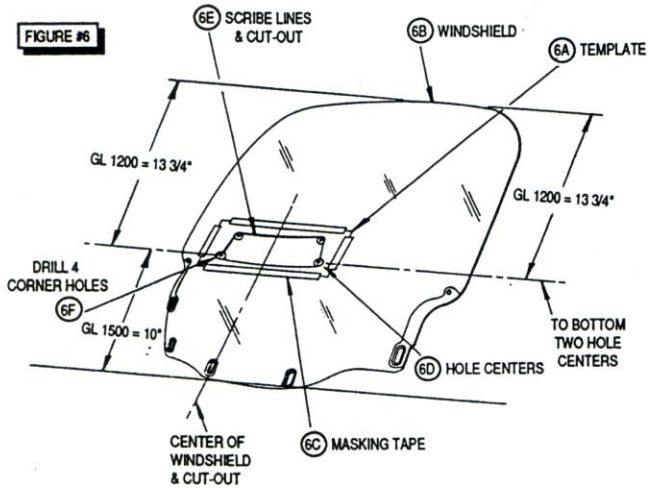

FIGURE #7

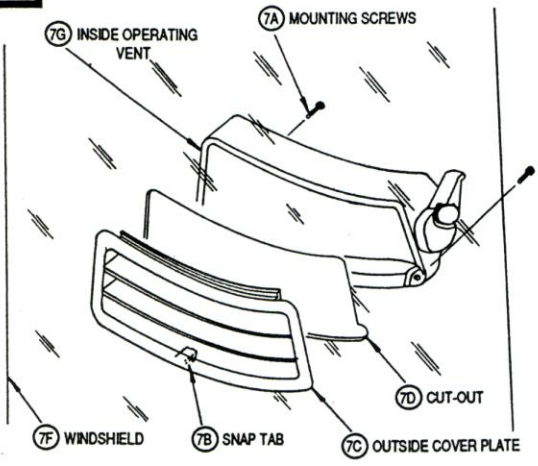

FIGURE #8

