

REVISED 7/23/07

ITEMS REQUIRED: (2) 10MM WRENCH, 8MM WRENCH, 5MM ALLEN WRENCH, PHILLIPS SCREWDRIVER, AND FLAT SCREWDRIVER.**PRE INSTALLATION:**

1. IF THIS MUD FLAP IS BEING INSTALLED ON A GL1500/6 WITH BBP'S ITEM NUMBER 2-437 RECEIVER HITCH, CUT OFF THE UPPER PART OF THE MUD FLAP WITH A UTILITY KNIFE AT THE RECESSED LINE. SEE FIGURE ONE. THE LOWER MOUNTING HOLES WILL BE USED TO MOUNT THE MUD FLAP
2. INSERT THE CHROMED METAL PLATE INTO THE LOWER PART OF THE MUD FLAP INTO THE CUSTOM SHAPED RECESS. ATTACH USING A PHILLIPS SCREW DRIVER, 8MM WRENCH, FOUR 5MM X .80 X 15 MACHINE SCREWS, FOUR CAP BOTTOMS, FOUR M5 FLAT WASHERS, AND FOUR M5 LOCK NUTS. THE LOWER TWO MACHINE SCREWS ALSO ATTACH THE LIGHT ASSEMBLY TO THE MUD FLAP. THE RED LENS OF THE MUD FLAP SHOULD FACE THE CHROMED METAL PLATE.
3. SNAP THE FOUR SMALL CHROME PLASTIC CAPS OVER THE FOUR BLACK PLASTIC CAP BOTTOMS.

GL1500/6 WITHOUT RECEIVER HITCH INSTALLATION INSTRUCTIONS**NOTE: REFER TO FIGURE 1.**

4. USING A 10MM WRENCH, REMOVE AND DISCARD THE TWO 6MM HEX BOLTS HOLDING THE OEM CROSS BAR.
5. KEEPING THE CROSS BAR IN POSITION, MOUNT THE MUD FLAP ON TOP OF THE CROSS BAR USING THE 10MM WRENCHES, TWO 6MM X 1.00 X 20 HEX BOLTS, TWO FLAT WASHERS, AND THE TWO STIFFENER STRAPS PROVIDED. THE STIFFENER STRAPS WILL BE MOUNTED USING THE TOP HOLE. SEE FIGURE 1. **NOTE:** THE GROUND WIRE IS TO BE ATTACHED BETWEEN THE MUD FLAP AND ONE OF THE STIFFENER STRAPS. ALSO, USE ONE OF THE STIFFENER STRAPS TO HOLD THE POWER WIRE AWAY FROM THE WHEEL.

GL1500/6 WITH RECEIVER HITCH INSTALLATION INSTRUCTIONS**NOTE: REFER TO FIGURE 1.**

6. WITH THE UPPER PORTION OF THE MUD FLAT ALREADY REMOVED, ATTACH THE MUD FLAP TO THE MOUNTING TABS LOCATED ON THE RECEIVER HITCH USING THE 10MM WRENCHES, TWO 6MM X 1.00 X 20 HEX BOLTS, AND TWO FLAT WASHERS AND THE TWO STIFFENER STRAPS PROVIDED. THE MUD FLAP WILL BE ATTACHED USING THE LOWER MOUNTING HOLES AND THE STIFFENER STRAPS MAY NEED TO BE ROTATED INWARD SLIGHTLY SO THAT THEY DO NOT PROTRUDE BELOW THE BOTTOM OF THE MUD FLAP. **NOTE:** THE GROUND WIRE IS TO BE ATTACHED BETWEEN THE MUD FLAP AND ONE OF THE STIFFENER STRAPS. ALSO, USE ONE OF THE STIFFENER STRAPS TO HOLD THE POWER WIRE AWAY FROM THE WHEEL.

GL1800 WITHOUT RECEIVER HITCH INSTALLATION INSTRUCTIONS**NOTE: REFER TO FIGURE 2.**

7. USING 5MM ALLEN WRENCH, REMOVE THE REAR FENDER PANEL BETWEEN THE TWO SADDLE BAGS. USING THE FLAT SCREWDRIVER, REMOVE THE TWO LOWER SPRING NUTS THAT HOLD THE REAR FENDER PANEL ON. THESE WILL NOT BE NEEDED.
8. REPLACE THE REAR FENDER PANEL. THE TWO SADDLEBAGS MAY NEED TO BE PRESSED TOGETHER TO GET THE PINS IN THE FENDER PANEL TO ALIGN WITH THE HOLES ON THE BIKE. INSTALL THE TWO UPPER SCREWS ONLY.
9. MOUNT THE TWO STIFFENER STRAPS TO THE BACK OF THE RUBBER MUD FLAP USING THE 10MM WRENCHES, TWO 6MM X 1.00 X 20 HEX BOLTS, TWO FLAT WASHERS, TWO LOCK NUTS, AND THE TWO STIFFENER STRAPS PROVIDED. USE THE SECOND HOLE IN EACH OF THE STRAPS AND THE UPPER, OUTERMOST HOLES ON THE MUD FLAP. THE TOP HOLE OF THE STRAPS SHOULD EXTEND OUT THE SIDES OF THE MUD FLAP. SEE FIGURE 2. **NOTE:** THE LIGHT WIRES SHOULD BE SUPPORTED BETWEEN THE MUD FLAP AND ONE OF THE STRAPS TO KEEP THE WIRES AWAY FROM THE TIRE.
10. ATTACH THE MUD FLAP ASSEMBLY TO THE BIKE USING THE 10MM WRENCHES, TWO 6MM X 1.00 X 20 HEX BOLTS, TWO FLAT WASHERS, AND TWO LOCK NUTS. THE MUD FLAP IS ATTACHED THROUGH THE TWO LOWER HOLES ON THE REAR FENDER PANEL WHERE THE SPRING NUTS WERE REMOVED.

GL1800 WITH RECEIVER HITCH INSTALLATION INSTRUCTIONS.**NOTE: REFER TO FIGURE 3.**

11. THESE INSTRUCTIONS ARE FOR MOUNTING TO BBP'S ITEM NUMBER 52-625 RECEIVER HITCH.
12. MOUNT THE TWO STIFFENER STRAPS TO THE BACK OF THE RUBBER MUD FLAP USING THE 10MM WRENCHES, TWO 6MM X 1.00 X 20 HEX BOLTS, TWO FLAT WASHERS, TWO LOCK NUTS, AND THE TWO STIFFENER STRAPS PROVIDED. USE THE SECOND HOLE IN EACH OF THE STRAPS AND THE UPPER, INNER HOLES ON THE MUD FLAP. THE TOP HOLE OF THE STRAPS SHOULD EXTEND OUT THE TOP OF THE MUD FLAP. SEE FIGURE 3. **NOTE:** THE LIGHT WIRES SHOULD BE SUPPORTED BETWEEN THE MUD FLAP AND ONE OF THE STRAPS TO KEEP THE WIRES AWAY FROM THE TIRE.

13. ATTACH THE MUD FLAP ASSEMBLY TO THE BIKE USING THE 10MM WRENCHES, TWO 6MM X 1.00 X 20 HEX BOLTS, TWO FLAT WASHERS, AND TWO LOCK NUTS. THE MUD FLAP IS ATTACHED THROUGH THE TWO MOUNTING HOLES IN THE RECEIVER HITCH.

ALL INSTALLS

14. SPLICE THE LIGHT WIRES INTO THE RUNNING LIGHTS OR BRAKE LIGHTS AS DESIRED.

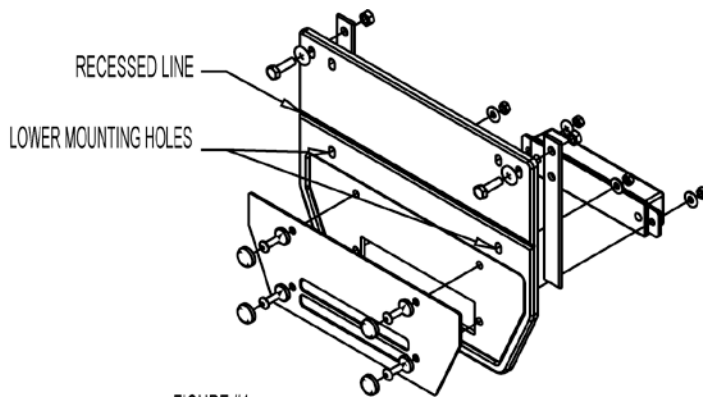

FIGURE #1

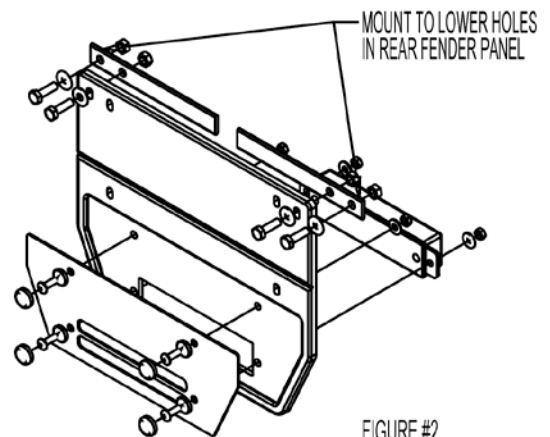

FIGURE #2

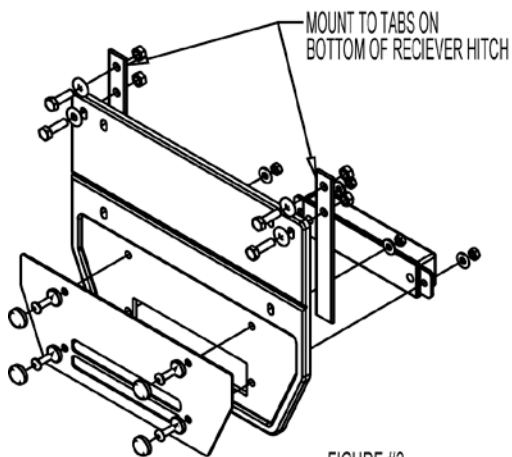

FIGURE #3