

BIG BIKE PARTS® INSTALLATION INSTRUCTIONS

PART NO. 21-4011

UNIVERSAL PASSENGER STEM

Copyright © 2008 by Big Bike Parts, Inc. No part of this instruction sheet may be reproduced without the written permission of Big Bike Parts, Inc.

8/14/2017

TOOLS NEEDED: 2 PLIERS, 6MM ALLEN WRENCH, 2.5MM ALLEN WRENCH, RULER, FILE, AND THREADLOCKER

NOTE: WE RECOMMEND USING THREADLOCKER ON ALL HARDWARE INSTALLED.

1. REMOVE THE OEM PEG FROM THE PASSENGER PEG MOUNTING BRACKET, BY REMOVING THE COTTER PIN OR E-CLIP AND THE PEG PIN WITH NEEDLE NOSE PLIERS.
2. MEASURE THE DISTANCE FROM THE PIN HOLE TO THE BACK OF THE PASSENGER PEG MOUNTING BRACKET. THEN TRANSFER THE DISTANCE ONTO THE DETENT PLATE (D). IF THE DISTANCE IS SHORTER THAN A SCRIBED LINE, BREAK THE DETENT PLATE (D) BY HOLDING THE DETENT PLATE (D) ON EACH SIDE OF THE NEXT SCRIBE LINE AND BENDING 90 DEGREES. SEE FIGURE 1.
3. USING A FILE FINE TUNE THE DETENT PLATE (D) BY FILING DOWN THE FLAT END OF THE DETENT PLATE (D) UNTIL THE HOLE IN THE DETENT PLATE (D) ALIGNS WITH THE HOLE IN THE MOUNTING BRACKET AND THE FLAT END OF THE DETENT PLATE (D) IS FLAT AGAINST THE BACK OF THE MOUNTING BRACKET.
4. SLIDE THE PASSENGER STEM (A) INTO THE PASSENGER PEG MOUNTING BRACKET AND REINSERT THE PIN. THEN MEASURE THE DISTANCE BETWEEN THE BACK OF THE PASSENGER STEM AND THE BACK OF THE PASSENGER PEG MOUNTING BRACKET WHEN THE TOP OF THE PASSENGER STEM (A) AND THE PASSENGER PEG MOUNTING BRACKET ARE PARALLEL.
5. IF THERE IS A GAP BETWEEN THE BACK OF THE PASSENGER STEM (A) AND THE PASSENGER PEG MOUNTING BRACKET PULL THE PASSENGER STEM (A) OUT OF THE PASSENGER PEG MOUNTING BRACKET AND USING A 2.5MM ALLEN WRENCH INSTALL THE TWO SET SCREWS (E) INTO THE TWO HOLES IN THE BACK OF THE PASSENGER STEM (A) AND ADJUST THEM SO THE SCREWS STICK OUT THE NOTED DISTANCE FROM STEP 4. IF THE ANGLE OF THE PASSENGER STEM (A) IS NOT TO YOUR PREFERENCE REMOVE THE PEG PIN AND ADJUST THE SET SCREWS (E) ACCORDINGLY. MAKE SURE THAT BOTH SET SCREWS STICK OUT THE SAME DISTANCE.
6. SLIDE THE SPRING (B) AND BALL (C) INTO THE SMALL HOLE IN THE PASSENGER STEM (A) AND PLACE THE DETENT PLATE (D) OVER THE BALL WITH THE FLAT END OF THE DETENT PLATE (D) PARALLEL WITH THE BACK OF THE PASSENGER STEM (A). IF THE PIN REMOVED IN STEP 1 WAS 6MM IN DIAMETER INSERT THE BUSHING (F) INTO THE PIN HOLE IN THE PASSENGER STEM (A) AND IF THE PIN WAS 8MM DISREGARD THE BUSHING (F). ALSO, IF THE PASSENGER PEG MOUNTING BRACKET IS WIDER THAN THE PASSENGER STEM (A) USE WASHERS (G), ON THE OPPOSITE SIDE AS THE DETENT PLATE (D), TO SHIM UNTIL TIGHT. THEN INSERT THE PASSENGER STEM (A) INTO THE PASSENGER PEG MOUNTING BRACKET AND REINSERT THE PEG PIN. SEE FIGURE 2.
7. SLIDE THE NEW PASSENGER PEG OR FLOOR BOARD OVER THE PASSENGER STEM (A), ROTATE TO YOUR PREFERRED POSITION, AND WITH AN ALLEN WRENCH TIGHTEN DOWN THE PROVIDED SCREW.
8. REPEAT STEPS 1-7 FOR THE OTHER SIDE.

FIG. 1

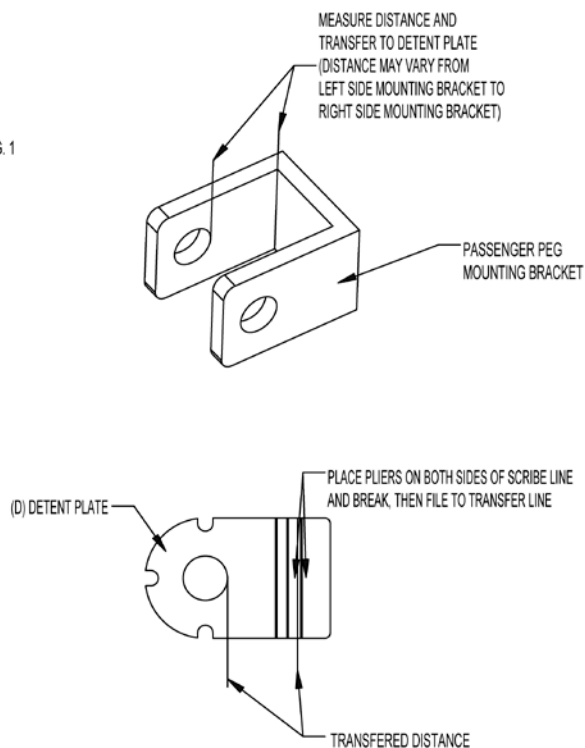

FIG. 2

