

Copyright © 2016 by Big Bike Parts, Inc. No part of this instruction sheet may be reproduced without the written permission of Big Bike Parts, Inc.

PART NO. 30-111LF

FORGED BAR FOG LIGHT KIT

9/20/2016

FITMENT: VICTORY CC/CR/MAGNUM/HARD BALL WITH FORGED BARS 2010-NEWER

TOOLS NEEDED:	4MM ALLEN WRENCH	5MM ALLEN WRENCH	6MM ALLEN WRENCH	10MM WRENCH	13MM WRENCH
	WIRE CUTTER/CRIMPER	SMALL FLAT SCREWDRIVER			

**PLEASE READ THROUGH AND UNDERSTAND THESE INSTRUCTIONS BEFORE BEGINNING.**

**ESTIMATED INSTALLATION TIME: 30 TO 45 MIN.**

**INSTALLATION:**

1. USING **FIG. 1** BELOW DETERMINE WHICH MOUNT IS FOR THE LEFT AND WHICH IS FOR THE RIGHT.
2. STARTING ON THE LEFT SIDE INSTALL THE LEFT MOUNT TO THE INSIDE OF THE LEFT FORGED BAR AS SHOWN IN **FIG. 1**.
3. USING A 6MM ALLEN WRENCH TIGHTEN THE BOLTS AND THEN INSTALL THE OTHER MOUNT ON THE RIGHT SIDE.
4. USING A 5MM ALLEN WRENCH AND A 10MM WRENCH TIGHT THE ADJUSTMENT BOLTS ON BOTH FOG LIGHTS. SEE **FIG. 2**.
5. INSTALL THE LIGHTS ON THE MOUNTS AS SHOWN IN **FIG. 2**. TIGHTEN THE NUTS ON EACH FOG LIGHT WITH A 13MM WRENCH.
6. USING A 4MM ALLEN WRENCH REMOVE THE FOUR SCREWS HOLDING THE CHIN FAIRING TO THE BIKE. REMOVE THE CHIN FAIRING AND SET IT ASIDE. THE CHIN FAIRING IS THE GRILLE/SPOILER THAT IS IN FRONT OF THE MOTOR AND BEHIND THE FRONT WHEEL.
7. USING A SMALL FLAT SCREWDRIVER REMOVE THE SWITCH PLUG FROM THE SWITCH CUTOUT NEAR THE RADIO DISPLAY.
8. TAKE THE THREE WIRE HARNESS WITH THE BLUE, ORANGE, AND GREEN WIRES AND ROUTE THE END WITH THREE FEMALE FLAT CONNECTORS FROM THE INSIDE OF THE DASH THROUGH THE SWITCH HOLE. SEE **FIG. 3**.
9. CONNECT THE BLUE WIRE TO TERMINAL 1 AND THE ORANGE WIRE TO TERMINAL 2. THE GREEN WIRE WILL NOT BE USED.
10. INSERT THE SWITCH INTO THE DASH WITH TERMINAL 1 AT THE BOTTOM OF THE SWITCH HOLE AS SHOWN IN **FIG. 3**.
11. FIND A PLACE TO MOUNT THE SUPPLIED RELAY. NOTE: USE A BOLT OR A WIRE TIE TO MAKE SURE THE RELAY IS SECURE AND WILL NOT MOVE WHEN RIDING THE BIKE.
12. TAKE THE TWO LONG BLACK WIRES FROM THE HARNESS AND CONNECT THE BULLET CONNECTORS TO EACH OF THE BLUE WIRES ON EACH LIGHT. SEE **FIG. 4**.
13. CONNECT THE TWO BLACK WIRES FROM THE NEW FOG LIGHTS TO A GROUND. NOTE: GROUND WIRES CAN BE CONNECTED TOGETHER AND THEN TO A COMMON GROUNDING POINT. RED RING TERMINALS ARE SUPPLIED FOR GROUNDING.
14. CONNECT THE BLUE WIRE FROM THE NEW SWITCH TO THE TERMINAL ON THE RELAY SHOWN IN **FIG. 4**.
15. CONNECT THE ORANGE WIRE FROM THE SWITCH TO A KEYED POWER SOURCE. A T-TAP CONNECTOR IS SUPPLIED FOR THIS CONNECTION.
16. ROUTE THE HARNESS WITH THE RED AND GREEN WIRES TO THE BIKES BATTERY. THE END WITH THE RING TERMINAL GOES TO THE BATTERY. DO NOT CONNECT TO BATTERY YET. CONNECT THE OTHER END TO THE RELAY AS SHOWN IN **FIG.4**.
17. CONNECT THE TWO BLACK WIRES FROM THE LIGHTS TO THE RELAY. SEE **FIG. 4**.
18. RECONNECT THE BATTERY AND INCLUDE THE NEW RED WIRE TO THE POSITIVE TERMINAL AND THE GREEN WIRE TO THE NEGATIVE TERMINAL.
19. REINSTALL AND TIGHTEN THE CHIN FAIRING.
20. TURN THE KEY AND THE NEW SWITCH TO THE "ON" POSITION AND MAKE SURE BOTH LIGHT TURN ON. ADJUST BOTH LIGHTS TO DESIRED POSITION.
21. AFTER A SHORT RIDE RECHECK ALL FASTENERS AND MAKE SURE WIRING IS SECURE.

**LEFT  
SIDE**

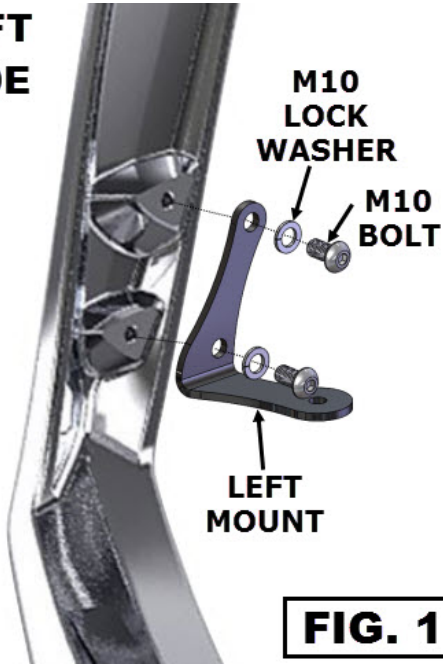

**FIG. 2**

