

Copyright © 2012 by Big Bike Parts, Inc. No part of this instruction sheet may be reproduced without the written permission of Big Bike Parts, Inc.

PART NO. 52-825

VERTICAL TRAILER HITCH

FITMENT: HONDA GOLDWING GL1800 2001-NEWER AND F6B

3/18/2019

TOOLS NEEDED:	6MM ALLEN WRENCH	5MM ALLEN WRENCH	12MM SOCKET WRENCH	14MM SOCKET WRENCH	14MM WRENCH
	LARGE ADJUSTABLE WRENCH	REMOVABLE THREAD LOCK COMPOUND	13MM SOCKET WRENCH	15MM WRENCH	17MM WRENCH

**PLEASE READ THROUGH AND UNDERSTAND THESE INSTRUCTIONS BEFORE BEGINNING. USE REMOVABLE THREAD LOCK ON ALL FASTENERS.**

**ESTIMATED INSTALLATION TIME: 90 TO 120 MIN. \*\*THREAD LOCK SHOULD BE USED ON ALL FASTENERS.\*\***

## INSTALLATION:

### SECTION ONE

1. PLACE MOTORCYCLE ON CENTER STAND.
2. USING A 5MM ALLEN WRENCH, REMOVE THE FOUR SCREWS (1A) SECURING THE REAR FENDER/SHROUD (1B) IN PLACE. GENTLY REMOVE REAR FENDER/SHROUD AND SET ASIDE. SEE FIGURE 1.
3. USING A 6MM ALLEN WRENCH, LOOSEN (DO NOT REMOVE) THE TWO RIGHT SIDE MUFFLER CLAMP BOLTS. REPEAT FOR LEFT SIDE (2A). SEE FIGURE 2.
4. USING A 12MM SOCKET, REMOVE THE RIGHT SIDE MUFFLER BRACKET BOLT (2C) AND GENTLY LOWER MUFFLER AND LET HANG. REPEAT FOR LEFT SIDE MUFFLER.
5. USING A 6MM ALLEN WRENCH, REMOVE THE RIGHT SIDE TWO SOCKET-HEAD CAP SCREWS SECURING THE PASSENGER HANDLE TO THE SEAT. REMOVE HANDLE AND SET ASIDE. REPEAT FOR LEFT SIDE PASSENGER HANDLE.
6. STARTING FROM THE PASSENGER AREA OF THE SEAT, WORK THE SEAT UP OUT OF THE PASSENGER BACKREST BUT DO NOT REMOVE SEAT. REACH UNDER SEAT AND DISCONNECT SEAT-WARMER WIRING HARNESS. CONTINUE LIFTING SEAT TO REMOVE AND SET SEAT ASIDE.
7. USING A 6MM ALLEN WRENCH, REMOVE THE TWO SOCKET-HEAD CAP SCREWS SECURING RIGHT SIDE PASSENGER FOOTREST. REMOVE FOOTREST AND SET ASIDE. REPEAT FOR LEFT SIDE PASSENGER FOOTREST.
8. REMOVE THE RIGHT SIDE-COVER BY GENTLY PULLING THE PANEL FREE. SET RIGHT SIDE-COVER ASIDE. REPEAT FOR LEFT-SIDE COVER.
9. USING A 5MM ALLEN WRENCH, REMOVE THE THREE BOLTS SECURING THE RIGHT SIDE FRAME COVER. SET FRAME COVER ASIDE. REPEAT FOR LEFT SIDE.
10. USING A 12MM SOCKET, REMOVE THE TWO HEX-HEAD BOLTS SECURING THE REAR RIGHT SIDE SADDLEBAG GUARD (2D). SET GUARD ASIDE. REPEAT FOR LEFT SIDE SADDLEBAG GUARD.
11. USING A 12MM SOCKET, REMOVE THE RIGHT SIDE FRONT SADDLEBAG FRAME MOUNTING BOLT (2E). REPEAT FOR LEFT SIDE FRONT SADDLEBAG FRAME MOUNT BOLT. THESE BOLTS WILL NOT BE REUSED.
12. USING A 5MM ALLEN WRENCH, REMOVE THE TWO SOCKET HEAD CAP SCREWS SECURING THE REAR SADDLEBAG CROSS BRACE (1D). SET CROSS BRACE ASIDE. THESE BOLTS WILL NOT BE REUSED.

### SECTION TWO

1. USING THE TWO M6 X 18MM SOCKET HEAD CAP SCREWS (D) AND TWO M6 FLAT WASHERS (C), INSTALL THE HITCH BRACE PLATE (3B) (COMPONENT M) WITH THE REAR SADDLEBAG CROSS BRACE IN PLACE BEHIND IT.
2. CAREFULLY MANEUVER TRAILER HITCH FRAME (L) INTO PLACE BENEATH SADDLEBAGS (3A).
3. ATTACH THE HITCH FRAME (L) TO THE HITCH BRACE PLATE (M) BY LOOSELY INSTALLING THE TWO M10 FLANGE HEAD BOLTS (I) ALONG WITH TWO M10 FLAT WASHERS (A) AND TWO M10 NYLON LOCK NUTS (3C) (COMPONENT G).
4. INSTALL THE M8 X 35MM HEX HEAD FLANGE BOLT (K) AND THE FLAT WASHER (O) INTO THE RIGHT SIDE FRONT SADDLEBAG FRAME MOUNT, THREADING IT INTO THE FRAME ONLY SO FAR AS TO ALLOW ABOUT 1/2MM OF BOLT SHANK TO PROTRUDE ON THE OTHER SIDE.
5. ALIGN RIGHT SIDE (SIDE WITH THREADED HOLE) OF HITCH FRAME (L) WITH PROTRUDING BOLT SHANK FROM PREVIOUS STEP. WHILE KEEPING THE HITCH FRAME (L) AS FLUSH AS POSSIBLE WITH THE INNER SURFACE OF THE FRONT SADDLEBAG FRAME MOUNTING BOSS, CONTINUE THREADING THE M8 X 35MM BOLT (K) INTO THE FRAME, ALLOWING THE THREADS TO ENGAGE THE THREADED HOLE AT THE TIP OF THE HITCH FRAME (L). MINIMAL CLEARANCE SHOULD EXIST BETWEEN THE FLAT SURFACE OF THE HITCH FRAME TIP AND THE MOUNTING BOSS FOR THE SADDLEBAG MOUNT. TIGHTEN THIS BOLT, THREAD LOCKER IS RECOMMENDED.
6. MOVING TO THE LEFT SIDE OF THE MOTORCYCLE, INSTALL THE M8 X 45MM HEX HEAD FLANGE BOLT (J) INTO THE LEFT SIDE FRONT SADDLEBAG FRAME MOUNT, THREADING THE BOLT COMPLETELY INTO THE SADDLEBAG FRAME MOUNT.
7. GENTLY PULL THE LEFT SIDE HITCH FRAME TIP (SIDE WITH SLOT) OVER THE PROTRUDING M8 X 45MM HEX HEAD FLANGE BOLT (J) FROM PREVIOUS STEP. INSTALL THE M8 FLAT WASHER (B) AND M8 NYLON LOCK NUT (H). TIGHTEN THE FASTENER, MAKING SURE THE BOLT DOES NOT BACK OUT OF THE SADDLEBAG FRAME MOUNT AS THE LOCK NUT ENGAGES THE THREADS.
8. USING A 14MM SOCKET AND 14MM BOX END WRENCH, TIGHTEN THE LOOSELY INSTALLED M10 BOLTS AND NYLON LOCKNUTS FROM STEP 3, SECTION TWO, MAINTAINING SYMMETRY OF THE HITCH FRAME IN RELATION TO THE MOTORCYCLE.
9. INSTALL HITCH (N) TONGUE INTO VERTICAL RECEIVER TUBE OF FRAME AND SECURE USING HITCH PIN (E) AND HAIRPIN COTTER PIN (F).
10. INSTALL THE BALL (P) ONTO THE HITCH TONGUE USING WASHER (Q) AND NUT (R) AND TIGHTEN SECURELY.

### SECTION THREE

1. TO COMPLETE INSTALLATION, REVERSE THE ORDER OF STEPS 1 THROUGH 9 OF SECTION ONE.
2. A M8 X 20MM ANTI-CHATTER BOLT (S) IS SUPPLIED WITH THE HITCH. IF NEEDED INSTALL THE BOLT INTO THE NUT JUST ABOVE THE HITCH PIN AND TIGHTEN.

## NOTICE

**IGNORING THE CONTENTS OF THESE INSTRUCTIONS MAY AFFECT THE PRODUCT PERFORMANCE AND FUNCTIONALITY. NOT FOLLOWING THESE INSTRUCTION MAY CAUSE DAMAGE TO THE PRODUCT OR THE VEHICLE TO WHICH IT IS BEING ATTACHED.**

## NOTICE

Big Bike Parts and it's Show Chrome Accessories® trailer hitch systems have been exclusively designed for use only on stock models. It will not work on any other motorcycle, and may not work or may interfere with aftermarket accessories. Any modification to any part of this hitch, including but not limited to altering the supplied hardware or improper installation could cause injury or death and immediately voids any and all warranties. Use of a trailer hitch on any motorcycle could void your motorcycle warranty and may increase your chances of injury or death. The end user of this product assumes all liability and responsibilities that may arise due to but not limited to, negligence from improper installation or use, including overloading, exceeding the recommended load limits of the motorcycle, trailer or trailer hitch and improper maintenance. Big Bike Parts total liability will be limited to the initial purchase price of this product or replacement of this product or replacement of this product at our discretion. 600 lbs. maximum GVWR, 60 lbs. maximum tongue weight, not to exceed GCWR for motorcycle.

**COMPONENTS:**

- A M10 FLAT WASHER (2)
- B M8 FLAT WASHER (1)
- C M6 FLAT WASHER (2)
- D M6 - 1.0 X 18MM SOCKET HEAD CAP SCREW (2)
- E HITCH PIN (1)
- F COTTER PIN (1)
- G M10 NYLON LOCK NUT (2)
- H M8 NYLON LOCK NUT (1)
- I M10 - 1.25 X 30MM HEAD FLANGE BOLT (2)
- J M8 - 1.25 X 45MM HEX HEAD FLANGE BOLT (1)
- K M8 - 1.25 X 35MM HEX HEAD FLANGE BOLT (1)
- L HITCH FRAME (1)
- M HITCH BRACE PLATE (1)
- N HITCH TONGUE (1)
- O 5/16 FLAT WASHER (1)
- P 1-7/8" TRAILER BALL (1)
- Q 3/4" LOCK WASHER (1)
- R 3/4" HEX NUT (1)
- S M8 X 20MM HEX BOLT (1) (ANTI CHATTER BOLT)

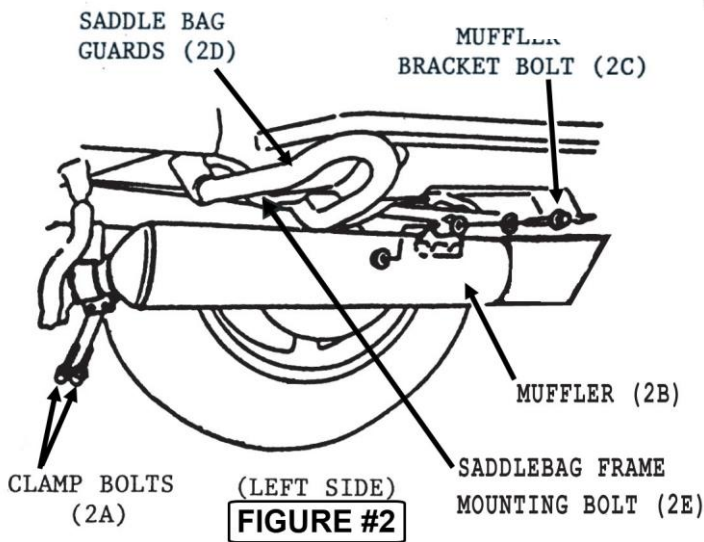
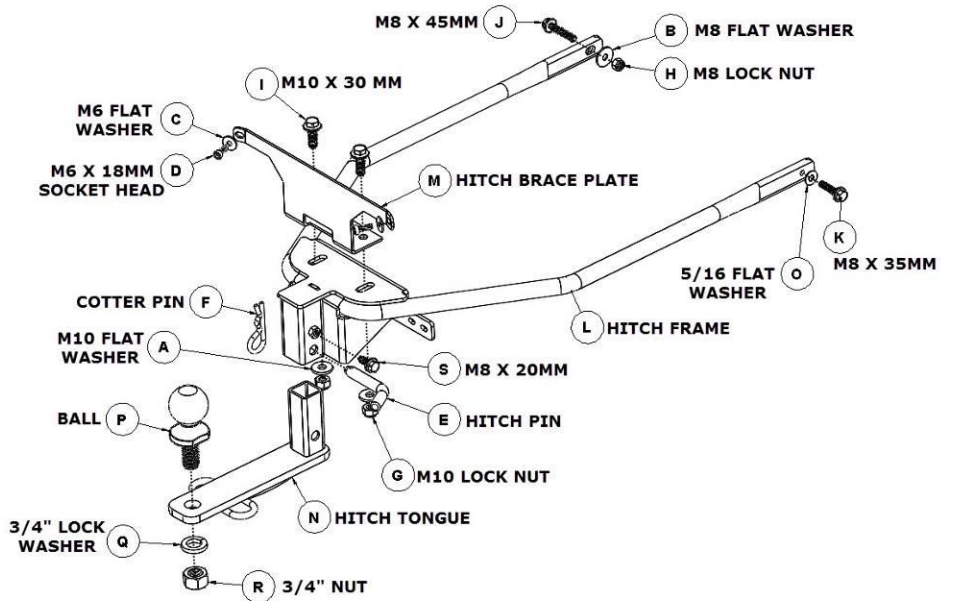

**FIGURE #2**

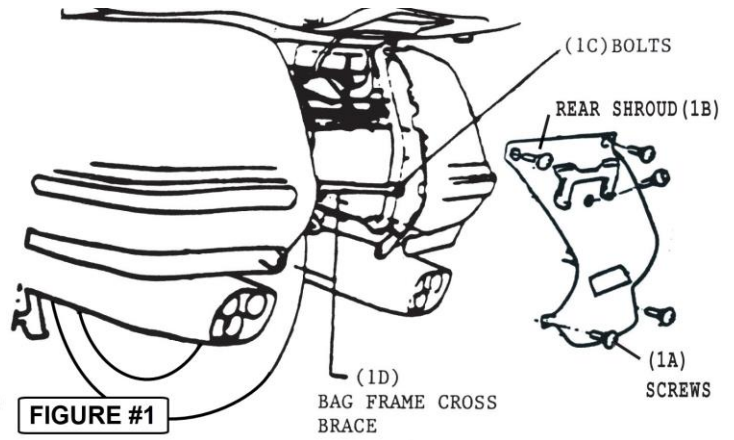

**FIGURE #1**

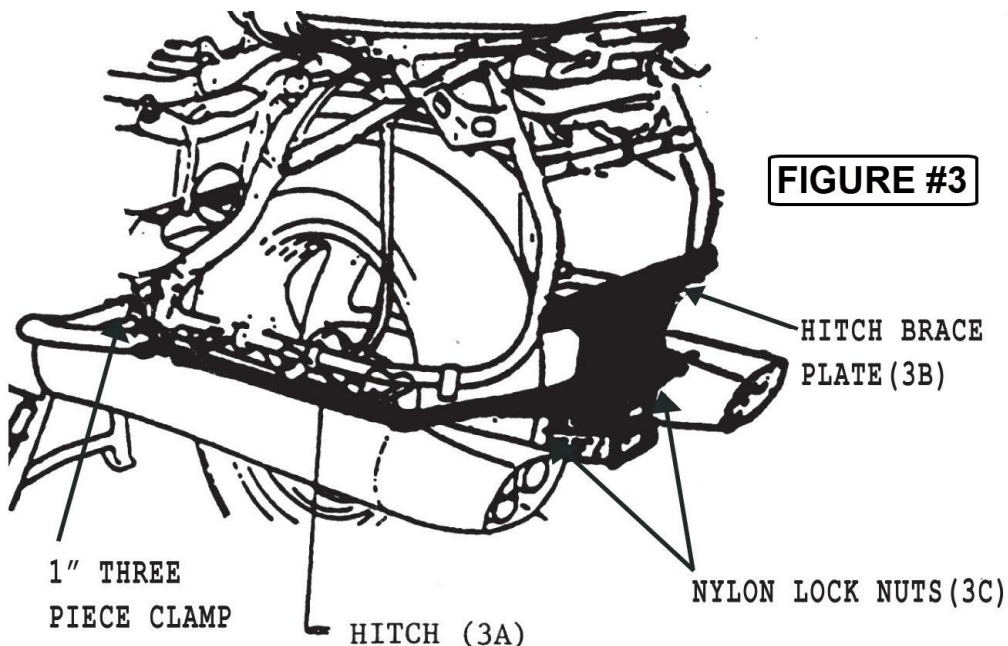

**FIGURE #3**