

Copyright © 2016 by Big Bike Parts, Inc. No part of this instruction sheet may be reproduced without the written permission of Big Bike Parts, Inc.

Part No. 52-915A/52-916A | LED RECTANGULAR FOG LIGHTS

FITMENT: GL1800 GOLDWING, F6B, 2001-2017

10/1/2019

TOOLS NEEDED:	PHILLIPS SCREWDRIVER	5MM ALLEN WRENCH	8MM WRENCH	HACK SAW BLADE	FLAT BLADE SCREWDRIVER
	FILE	THREAD LOCK COMPOUND (REMOVABLE)		ESTIMATED INSTALLATION TIME: 90 TO 120 MIN.	
HARDWARE (INCLUDED):	(2E) RIGHT LIGHT MOUNT – 1 PC (2F) LEFT LIGHT MOUNT – 1 PC (2G) LARGE RUBBER GROMMET – 6 PCS (3H) SILVER FLANGE COLLAR – 6 PCS (3I) M6 FLAT WASHER – 6 PCS (3J) M6 X 32MM LONG HEX SCREW – 3 PCS (3K) 6MM X 4MM LONG SPACER – 1 PC (4L) M6 X 50MM LONG HEX SCREW – 3 PCS	(4M) 6MM X 16MM LONG SPACER – 2 PCS (4N) 6MM X 20MM LONG SPACER – 1 PC (5O) RIGHT LIGHT BRACKET – 1 PC (5P) LEFT LIGHT BRACKET – 1 PC (5Q) RIGHT LED LIGHT – 1 PC (5R) LEFT LED LIGHT – 1 PC (5S) M4 X 10MM PAN HEAD SCREW – 6 PCS (6T) GOLD FLANGE COLLAR – 4 PCS	(6U) M5 X 20MM LONG PAN HEAD SCREW – 4 PCS (8V) LIGHT SWITCH HARNESS – 1 PC (8W) RELAY/JUMPER HARNESS – 1 PC (8X) RELAY – 1 PC (8Y) HIGH BEAM JUMPER – 1 PC (8Z) DRL/TURN SIGNAL HARNESS – 2 PCS Misc. WIRE TIES – 3 PCS		

NOTICE: THESE LIGHTS ARE DESIGNED TO FUNCTION PROPERLY ON A STOCK GL1800 ONLY. BBP IS NOT RESPONSIBLE FOR ANY ISSUES THAT MAY BE CAUSED BY OTHER AFTERMARKET PRODUCTS AND ACCESSORIES. PLEASE READ THROUGH AND UNDERSTAND THESE INSTRUCTIONS BEFORE BEGINNING. USE A REMOVABLE THREAD LOCK COMPOUND ON ALL SCREWS

***NOTE: RECTANGULAR STYLE LOWER COWL REQUIRED FOR THESE LIGHTS. STANDARD ON 2012 AND NEWER BIKES. FOR 2010 AND OLDER USE BIG BIKE PARTS PART NUMBER 52-908.**

****2001-2005 GL1800 AND F6B WILL NEED TO HAVE THE DAY TIME RUNNING LIGHTS AND TURN SIGNALS SPLICED INTO THE BIKES WIRING. (SEE NOTE)**

NOTE: IF INSTALLING ON A GL1800 VALKYRIE YOU WILL NEED TO PURCHASE ADMORE LIGHTING™ PART NUMBER A-GL18RFL IN ORDER TO MAKE TURN SIGNALS FUNCTION.

INSTALLATION:

- DISCONNECT THE NEGATIVE BATTERY CABLE.
- USING A 5MM ALLEN WRENCH REMOVE THE SIX ALLEN SCREWS (1A) AND THE TWO PUSH PINS (1C) THAT HOLD THE LOWER COWL (1B) ON THE BIKE. SEE FIG. 1.
- REMOVE THE COWL AND USING A HACK SAW BLADE REMOVE THE TWO KNOCK OUTS (1D). USE A FILE TO SMOOTH OUT THE CUTS AND REMOVE THE SHARP EDGES.
- STARTING WITH THE RIGHT LIGHT MOUNT (2E) INSTALL THE THREE LARGE RUBBER GROMMETS IN THE HOLES SHOWN IN FIG. 2. THEN INSTALL THE THREE GROMMETS AS SHOWN IN THE LEFT LIGHT MOUNT (2F) AS SHOWN IN FIG. 2.
- USING AN 8MM WRENCH REMOVE THE RIGHT AND LEFT BLOCK OFF THAT ARE SHOWN IN FIG. 3 AND FIG. 4. THE BOLTS WILL NOT BE REUSED.
- TAKE THE RIGHT LIGHT MOUNT (2E) AND PUSH THREE SILVER FLANGE COLLARS (3H) INTO THE BACK OF THE LARGE RUBBER GROMMETS (2G) AS SHOWN IN FIG. 3.
- USING THE M6 X 32MM LONG HEX HEAD SCREWS (3J), M6 FLAT WASHERS (3I), AND 6MM X 4MM LONG SPACER (3K) ASSEMBLY THE RIGHT MOUNT TO THE BIKE. SEE FIG. 3. **NOTE: BE SURE TO REINSTALL THE RIGHT BLOCK OFF AS SHOWN.**
- TAKE THE LEFT LIGHT MOUNT (2F) AND PUSH THREE SILVER FLANGE COLLARS (3H) INTO THE BACK OF THE LARGE RUBBER GROMMETS (2G) AS SHOWN IN FIG. 4.
- USING THE M6 X 50MM LONG HEX HEAD SCREWS (4L), M6 FLAT WASHERS (3I), 6MM X 16MM LONG SPACERS (4M) AND 6MM X 20MM LONG SPACER (4N) ASSEMBLY THE LEFT MOUNT TO THE BIKE. SEE FIG. 4. **NOTE: BE SURE TO REINSTALL THE LEFT BLOCK OFF AS SHOWN.**
- TAKE THE RIGHT LED LIGHT (5Q) AND ATTACH THE RIGHT LIGHT BRACKET (5O) TO IT USING THREE OF THE M4 X 10MM PAN HEAD SCREWS (5S). SEE FIG. 5.
- REPEAT STEP 10 WITH LEFT LED LIGHT (5R) AND THE LEFT LIGHT BRACKET (5P).
- TAKE THE RIGHT LIGHT ASSEMBLY AND INSTALL IT IN THE RIGHT LIGHT MOUNT AS SHOWN IN FIG. 6. **NOTE: THE TAB SHOULD GO BETWEEN THE WASHER AND THE SCREW HEAD AS SHOWN IN THE RIGHT VIEW OF FIG. 6.**
- USING TWO M5 X 20MM LONG SCREW (6U) AND TWO GOLD FLANGE COLLARS (6T) ASSEMBLE TOGETHER AS SHOWN IN FIG. 6.
- FIND THE OEM CONNECTOR THAT IS TAPED TO THE FRONT RIGHT SIDE OF THE MOTOR. REMOVE THE TAPE AND REMOVE THE CAP FROM THE CONNECTOR.
- PLUG THE LIGHT INTO THE OEM CONNECTOR.
- REPEAT STEPS 12 THROUGH 15 FOR THE LEFT LIGHT ASSEMBLY. **NOTE: DO NOT REINSTALL COWL AT THIS POINT.**
- REMOVE THE TRIM FROM THE BACK LEFT SIDE OF THE FAIRING THAT IS NEXT TO THE RADIO CONTROLS.
- USING A SCREWDRIVER PUSH THE CENTER PIN IN ON THE FOUR RIVETS THAT HOLD THE LEFT POCKET TO THE FAIRING AND REMOVE THE POCKET. SEE FIG. 7.
- USING A 5MM ALLEN WRENCH REMOVE THE TWO ALLEN BOLTS THAT HOLD THE RADIO CONTROLS TO THE FAIRING. SEE FIG. 7.
- LIFTING FROM THE LEFT SIDE REMOVE THE RADIO CONTROL, YOU WILL NEED TO UNPLUG THREE CONNECTORS TO REMOVE IT FROM THE BIKE.
- REMOVE THE BACK PANEL FROM THE UNIT AS SHOWN IN FIG. 8. **TIP: INSERT A SCREWDRIVER IN THE SMALL CUTOUTS ON THE SIDES TO RELEASE THE COVER.**
- REMOVE THE TWO PHILLIPS SCREWS HOLDING THE BLANK SWITCH IN AND SET ASIDE. THE SCREWS WILL BE REUSED.
- INSTALL THE SWITCH (8V) IN THE SWITCH SLOT AND INSTALL THE TWO SCREWS YOU REMOVED IN STEP 22.
- REINSTALL THE BACK COVER FEEDING THE WIRES FROM THE NEW SWITCH THROUGH THE SAME OPENING AS THE OTHER WIRES.
- IF YOU WANT THE LIGHT TO TURN OFF WHEN YOUR HIGH BEAMS ARE TURNED ON CONNECT THE RELAY/JUMPER HARNESS (8W) TO THE LIGHT SWITCH HARNESS (8V). THEN INSTALL THE RELAY (8X) TO THE RELAY/JUMPER HARNESS (8W). SEE FIG. 8.
- IF YOU WANT THE LIGHT TO BE CONTROLLED ONLY BY THE SWITCH AND STAY ON WITH THE HIGH BEAMS DO NOT USE HARNESS (8W) AND RELAY (8X). **NOTE: DO NOT DISCARD THESE ITEMS. YOU MAY WANT TO INSTALL THEM AT A LATER TIME.**
- FIND THE BLACK 4 PIN MALE CONNECTOR IN THE FAIRING. IT SHOULD BE BELOW THE AREA THAT THE RADIO CONTROL WAS MOUNTED. PLUG THE SWITCH INTO THE CONNECTOR.
- REASSEMBLE THE RADIO AND SIDE POCKET IN REVERSE ORDER AND RECONNECT THE BATTERY CABLE.
- RELEASE THE RUBBER TRIM MOLDING ON BOTH REAR VIEW MIRRORS. TWIST THE MIRRORS FORWARD TO GAIN ACCESS TO THE CONNECTORS FOR THE LIGHTS.
- ROUTE THE END WITH THE SINGLE CONNECTOR ON EACH OF THE DRL/TURN SIGNAL HARNESSES INTO THE FAIRING AND DOWN TO THE FOG LIGHTS.
- UNPLUG THE CONNECTOR IN EACH MIRROR AND ADD IN THE NEW HARNESS AS SHOWN IN FIG. 9. CONNECT THE OTHER END TO EACH FOG LIGHT. SEE FIG. 5.
- **NOTE: FOR 2001-2005 GL1800, AND F6B MODELS YOU WILL NEED TO CUT OFF THE END WITH TWO CONNECTORS AND SPLICE THE RED WIRES FOR EACH TURN SIGNAL, THE BLUE WIRES FOR EACH RUNNING LIGHT AND THE BLACK WIRES ARE FOR GROUNDS.**
- TURN THE FOG LIGHT ON AND USING A PHILLIPS SCREWDRIVER ADJUST THE FOG LIGHTS TO YOUR DESIRED SETTING.
- TURN ON THE RIGHT AND LEFT TURN SIGNALS TO MAKE SURE THEY FUNCTION PROPERLY.
- USE WIRE TIES TO MAKE SURE ALL WIRES ARE SECURE.
- REINSTALL THE LOWER COWL (1B) MAKING SURE THE FAIRING TABS (10A) ARE IN FRONT OF THE CLIP NUTS ON THE COWL. SEE FIG. 10. INSTALL THE TWO UPPER MOST SCREWS FIRST WHEN REINSTALLING THE LOWER COWL.
- REINSTALL THE RUBBER TRIM MOLDING ON EACH MIRROR.

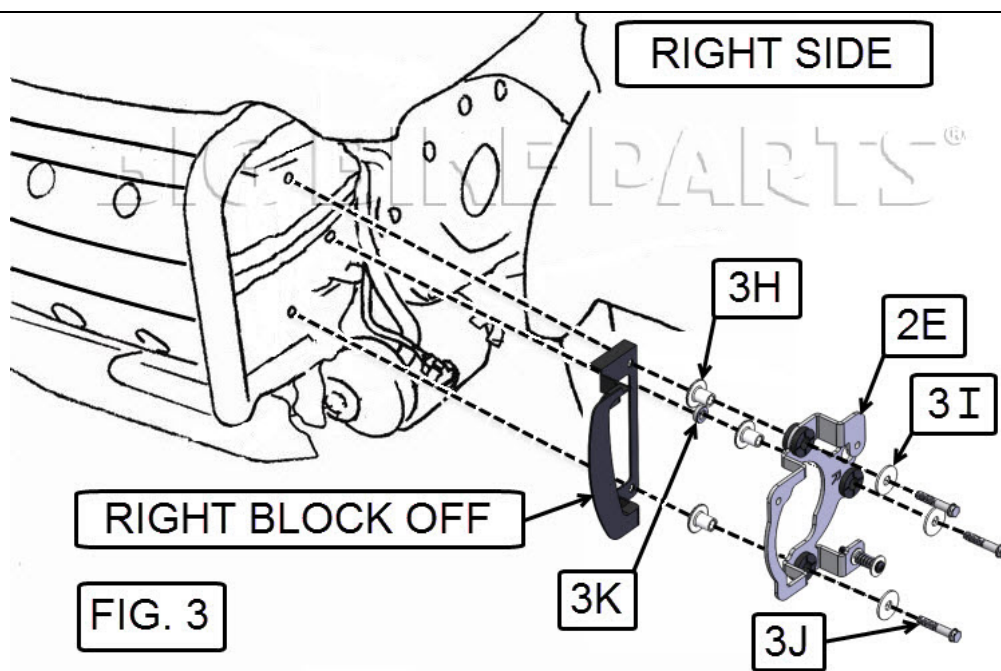
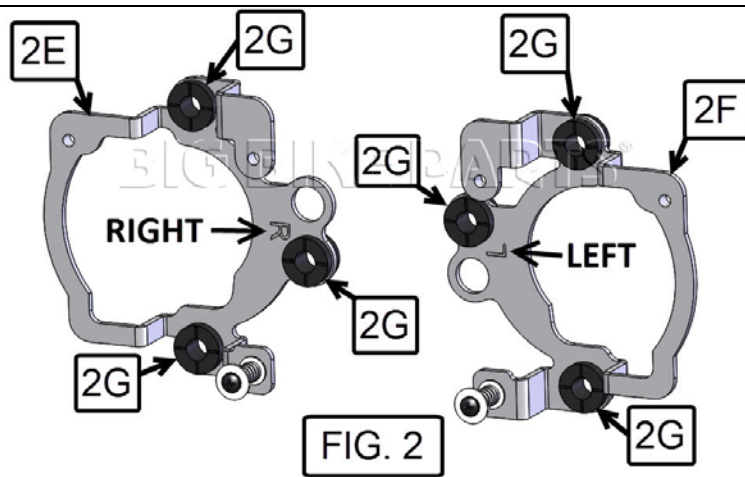
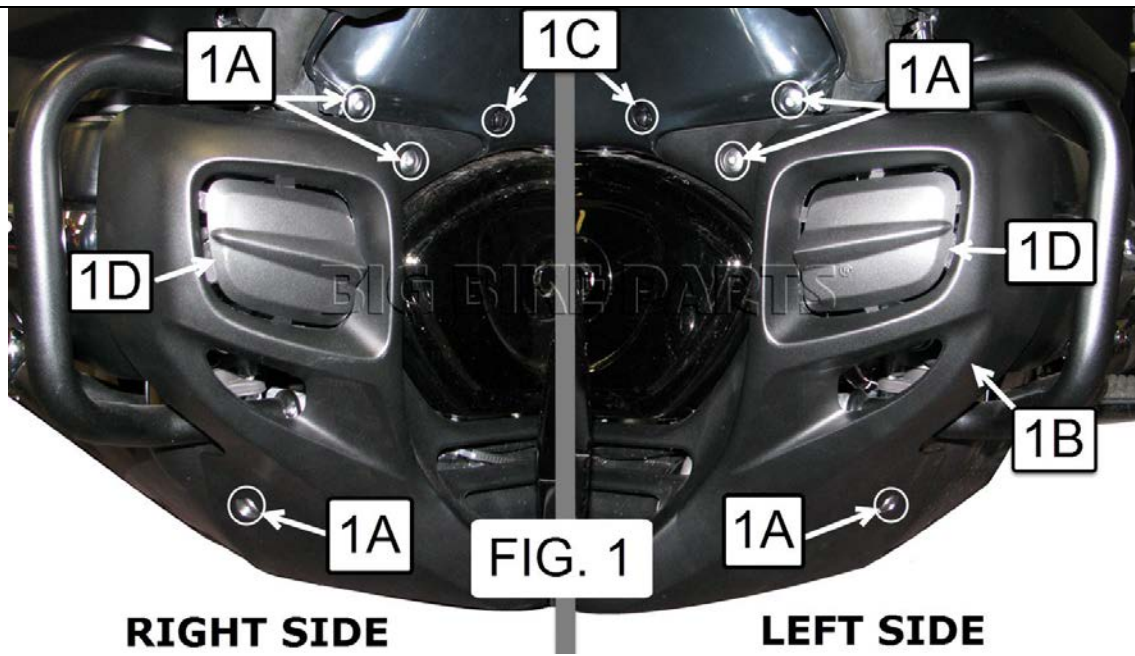

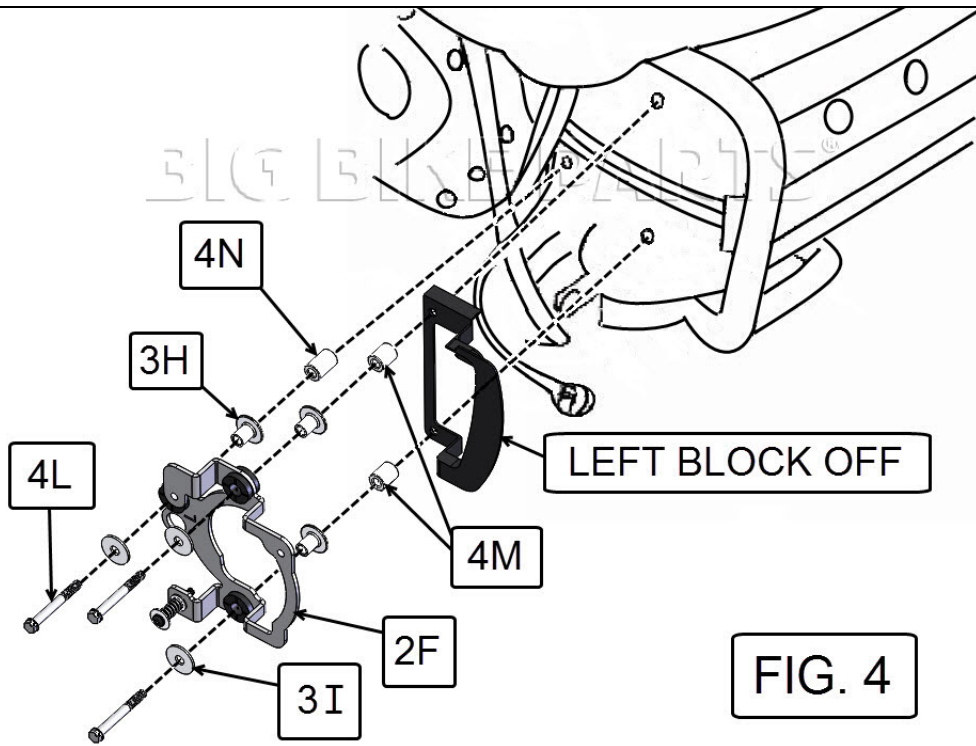

FIG. 4

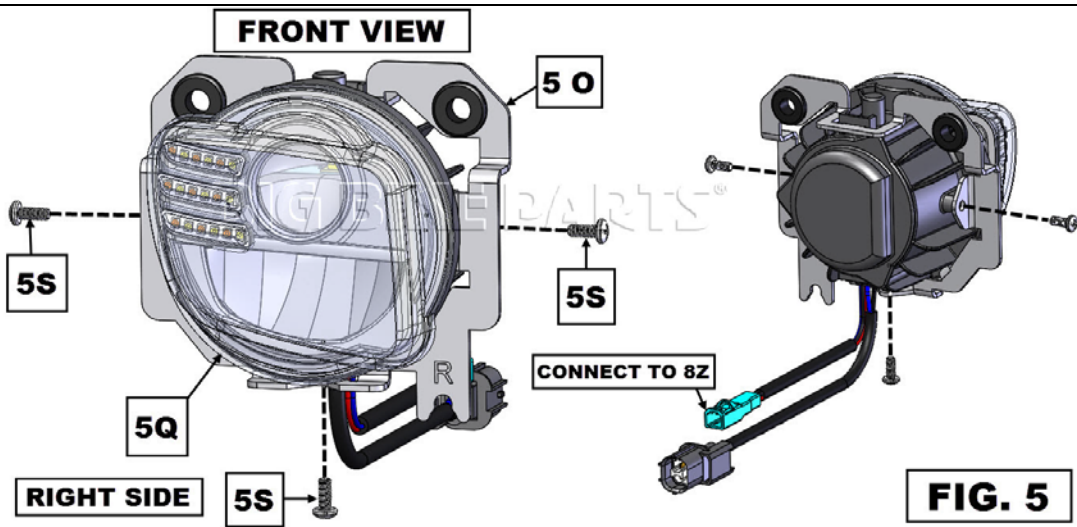

FIG. 5

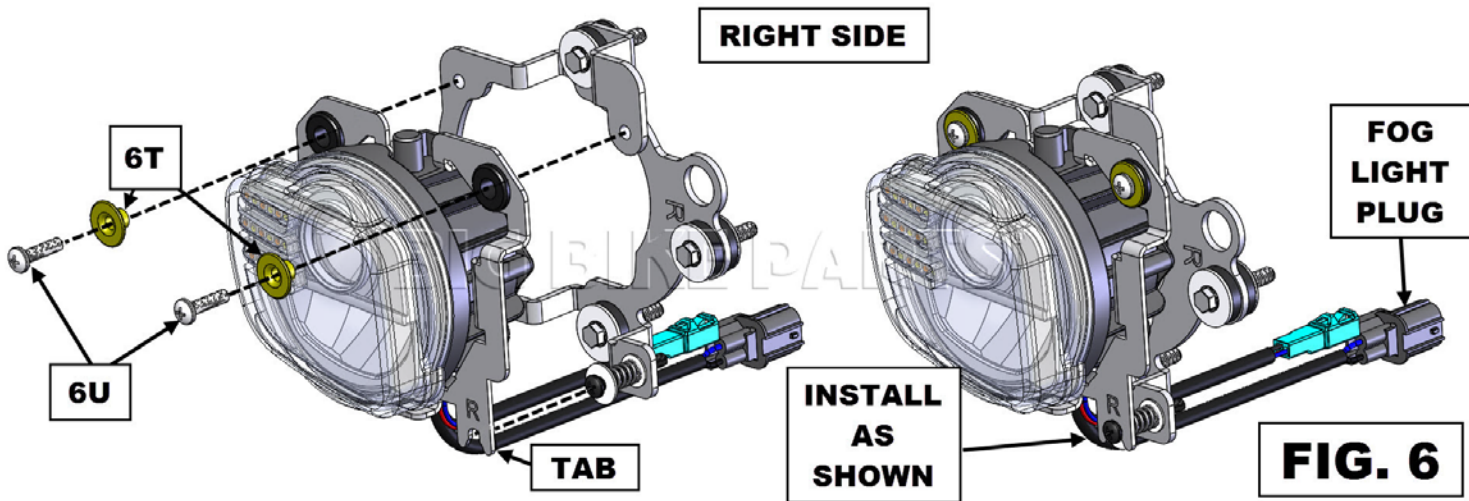

FIG. 6



NOTICE

IGNORING THE CONTENTS OF THESE INSTRUCTIONS MAY AFFECT THE PRODUCT PERFORMANCE AND FUNCTIONALITY. NOT FOLLOWING THESE INSTRUCTION MAY CAUSE DAMAGE TO THE PRODUCT OR THE VEHICLE TO WHICH IT IS BEING ATTACHED.

NOTICE

ADDING MULTIPLE ACCESSORIES TO A CIRCUIT MAY CAUSE ISSUES WITH SOME ACCESSORIES

