

Copyright © 2018 by Big Bike Parts, Inc. No part of this instruction sheet may be reproduced without the written permission of Big Bike Parts, Inc.

PART NO. SEE FITMENT

ARMREST ADJUSTMENT

11/18/2019

FITMENT: 30-202, 30-203, 41-159, 41-309, 52-672, 52-926, 91-313

TOOLS NEEDED: 6MM ALLEN WRENCH

2MM ALLEN WRENCH

1/4" ALLEN WRENCH

3/32" ALLEN WRENCH

REMOVABLE THREAD LOCK

PLEASE READ THROUGH AND UNDERSTAND THESE INSTRUCTIONS BEFORE BEGINNING. "USE REMOVABLE THREAD LOCK ON ALL FASTENERS"

INSTALLATION:

1. BE SURE THE THREADS OF THE SET SCREWS AND PIVOT BOLT ARE CLEAN AND DRY. APPLY REMOVABLE THREAD LOCK TO EACH OF THEM.
2. ASSEMBLE THE ARMREST ACCORDING TO FIG. 1.
3. WITH THE SET SCREWS LOOSE, TIGHTEN THE PIVOT BOLT UNTIL THE ARM HAS RESISTANCE WHEN ROTATED BY HAND (FIG. 2).
4. WHILE HOLDING THE PIVOT BOLT WITH THE ALLEN WRENCH (FIG. 2), MOVE THE ARM BACK AND FORTH TO CHECK THAT IT IS ADJUSTED TO WHERE YOU WANT IT. TIGHTEN OR LOOSEN THE PIVOT BOLT ACCORDINGLY.
5. WHILE HOLDING THE PIVOT BOLT IN PLACE WITH THE ALLEN WRENCH, TIGHTEN EACH SET SCREW COMPLETELY AGAINST THE PIVOT BOLT. (DO NOT TIGHTEN OR LOOSEN THE PIVOT BOLT WHEN THE SET SCREWS ARE TIGHT.)
6. LET THE REMOVABLE THREAD LOCK CURE FOR 24 HOURS BEFORE USE.

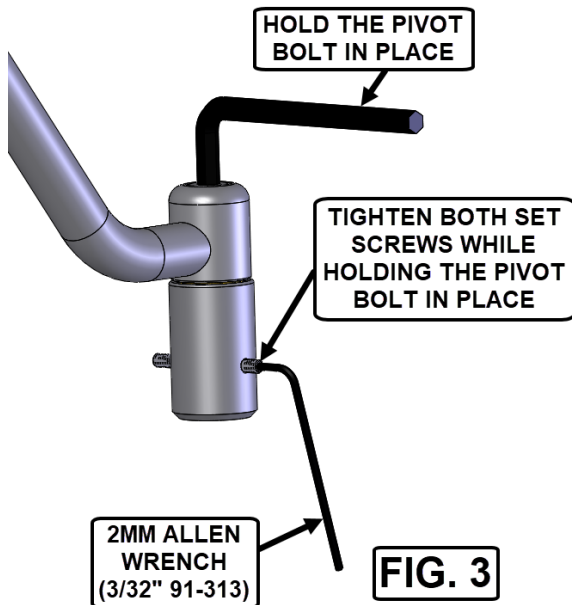
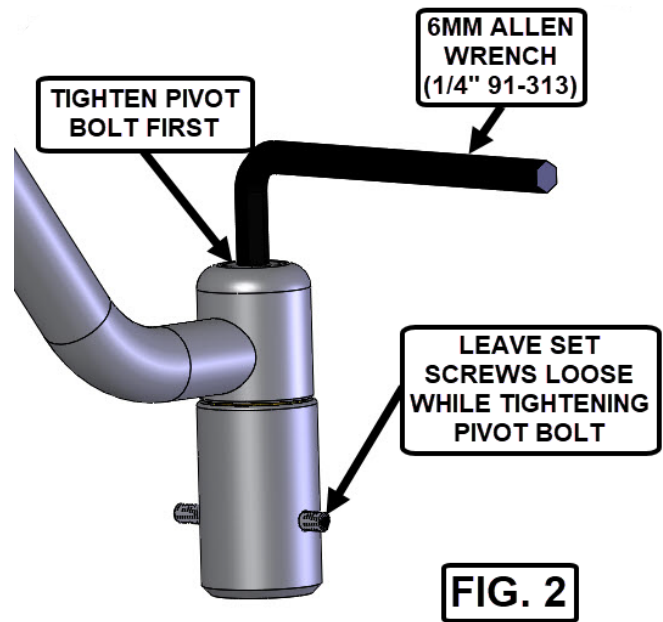
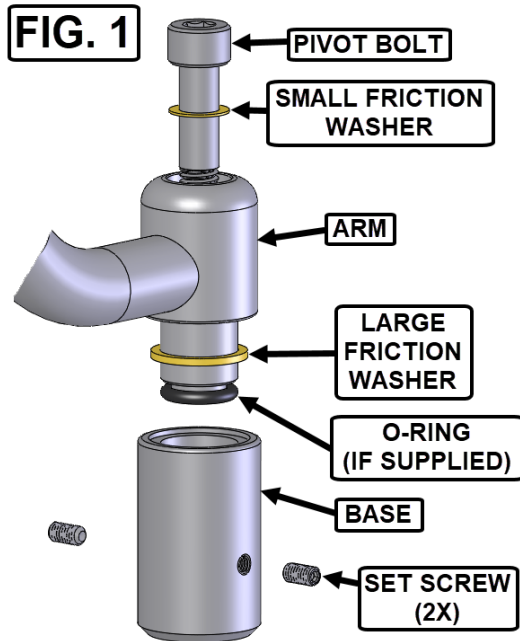

NOTICE

IGNORING THE CONTENTS OF THESE INSTRUCTIONS MAY AFFECT THE PRODUCT PERFORMANCE AND FUNCTIONALITY. NOT FOLLOWING THESE INSTRUCTION MAY CAUSE DAMAGE TO THE PRODUCT OR THE VEHICLE TO WHICH IT IS BEING ATTACHED.