

Copyright © 2016 by Big Bike Parts, Inc. No part of this instruction sheet may be reproduced without the written permission of Big Bike Parts, Inc.

PART NO. 63-627L

ELLIPTICAL LED DRIVING LIGHT BAR KIT

FITMENT: YAMAHA V STAR 1100 CLASSIC/CUSTOM

10/6/2016

TOOLS NEEDED:	PHILLIPS SCREWDRIVER	2MM ALLEN WRENCH	4MM ALLEN WRENCH	6MM ALLEN WRENCH	8MM WRENCH
DRILL	13MM SOCKET WRENCH	10MM WRENCH	12MM SOCKET WRENCH	13/16" DRILL BIT	THREAD LOCK COMPOUND

**PLEASE READ THROUGH AND UNDERSTAND THESE INSTRUCTIONS BEFORE BEGINNING. USE REMOVABLE THREAD LOCK ON ALL SCREWS.**

**ESTIMATED INSTALLATION TIME: 60 TO 90 MIN.**

**INSTALLATION:**

- DISCONNECT THE NEGATIVE BATTERY CABLE.
- USING THE PHILLIPS SCREWDRIVER, REMOVE THE TWO SCREWS HOLDING THE FRONT COVER TO THE HEADLIGHT HOUSING, AND THEN DISCONNECT THE HEADLIGHT AND SET IT ASIDE.
- DISCONNECT THE TURN SIGNALS FROM INSIDE THE HEADLIGHT HOUSING, NOTING AS TO WHICH ONE IS THE LEFT AND RIGHT TURN SIGNAL.
- REMOVE THE OEM LIGHT BAR USING A 6MM ALLEN WRENCH TO REMOVE THE TWO SOCKET HEAD CAP SCREWS HOLDING IT TO THE FRONT OF THE TRIPLE TREE.
- REMOVE THE TURN SIGNALS FROM THE LIGHT BAR BY USING THE 8MM AND 10MM WRENCHES TO REMOVE THE NUT AND BOLT ON THE BACK OF THE TURN SIGNAL, THEN PULL THE TURN SIGNAL AND THE WIRES OUT OF THE LIGHT BAR.
- USING THE 12MM SOCKET WRENCH AND 6MM ALLEN WRENCH, REMOVE THE TWO NUTS AND BOLTS HOLDING THE HEADLIGHT BRACKET TO THE TOP OF THE TRIPLE TREE, AND SLIDE THE NEW LIGHT BAR BRACKET BETWEEN THE TOP OF THE TRIPLE TREE AND UNDER THE HEADLIGHT BRACKET. REINSTALL THE NUTS AND BOLTS JUST REMOVED AND TIGHTEN DOWN.
- INSTALL THE LED LIGHTS (E) ONTO THE LIGHT BAR (D) USING THE LOCK NUTS (F) PROVIDED WITH THE LED LIGHTS. POSITION THE LIGHTS. TIGHTEN WITH A 13MM SOCKET.

**NOTE: STEPS 8,9,10, AND 12 ARE FOR INSTALLING OEM TURN SIGNALS WITH 62-112T ADAPTERS. (SOLD SEPARATELY)**

- INSTALL EACH OEM TURN SIGNAL (G) ONTO THE NEW TURN SIGNAL ADAPTER (H) ROUTING THE WIRES THROUGH THE HOLE IN THE ADAPTERS. USING THE BOLTS REMOVED IN STEP 6; SECURE THE TURN SIGNAL TO THE ADAPTER.
- ROUTE THE OEM TURN SIGNAL WIRES AND SPOT LIGHT WIRE UNDER THE LIGHT BAR (D). YOU MAY HAVE TO CUT OFF OEM BULLET CONNECTORS AND ADD NEW ONES AFTER THEY ARE ROUTED.
- THE TURN SIGNAL ADAPTERS (H) WITH OEM TURN SIGNALS (G) NEED TO BE POSITIONED INTO THE LOWER ENDS OF THE NEW LIGHT BAR (D) AND SECURED WITH THE SET SCREWS (K), THERE ARE THREE SET SCREWS ON EACH SIDE.

**NOTE: THERE ARE THREE DIFFERENT SETS OF MOUNTING HOLES ON THE LIGHT BAR. THIS IS FOR ADJUSTABILITY BETWEEN BIKES. CHOOSE THE ONES THAT WILL GET THE LIGHT BAR CLOSEST TO THE FORKS WITHOUT HITTING ANYTHING.**

- USING THE M6 - 1.0 X 16MM LONG BUTTON SOCKET HEAD CAP SCREWS AND LOCK WASHERS (C), INSTALL THE LIGHT BAR (D) ONTO THE MOUNTING PLATE (A). TIGHTEN SECURELY WITH A 4MM ALLEN WRENCH.
- RE-ROUTE THE OEM TURN SIGNAL WIRES INTO THE HEADLIGHT HOUSING AND RE-CONNECT AS THEY WERE.
- LOCATE YOUR BIKE'S BATTERY, FUSE BLOCK, AND/OR ACCESSORY TERMINALS AND WIRE ACCORDING TO THE DIAGRAM ON BACK.

**WIRING THE DRIVING LIGHTS (SEE FIG. 2)**

**NOTE: IF A 13-207/52-605L SWITCH BLOCK IS PURCHASED, STEPS C & E CAN BE SKIPPED AND PLUG ONE OF THE SWITCHES INTO THE RELAY.**

- CONNECT THE BLACK WIRES TO THE CONNECTORS ON EACH LIGHT. THE OTHER ENDS OF THE BLACK WIRES CONNECT TO THE RELAY AS SHOWN IN THE DIAGRAM. THE RELAY CAN BE LOCATED UNDER THE SIDE COVER OR SEAT. THE WIRES CAN BE ROUTED THROUGH THE LIGHT BAR AND UNDER THE FUEL TANK OR ALONG THE INSIDE OF THE FRAME TO KEEP THEM OUT OF SIGHT.
- THE WIRE HARNESS WITH THE RED AND GREEN WIRES CONNECTS THE BATTERY TO THE RELAY. THIS HARNESS ALSO HAS AN INLINE FUSE ON THE RED WIRE. THE ENDS WITH THE RING TERMINALS SHOULD BE PLACED UNDER THE SCREWS THAT HOLD THE BATTERY CABLES TO THE BATTERY TERMINALS. CONNECT THE OTHER ENDS OF THE HARNESS TO THE RELAY AS SHOWN IN THE DIAGRAM.

**NOTE: IF A BIG BIKE PARTS ACCESSORY SWITCH BLOCK (13-207 OR 52-605) HAS BEEN PURCHASED YOU CAN USE THIS TO CONTROL THE LIGHTS IN PLACE OF THE SWITCH THAT HAS BEEN SUPPLIED WITH THE DRIVING LIGHT KIT. FOLLOW THE WIRING INSTRUCTIONS IN THE SWITCH BLOCK KIT FOR DIRECTIONS ON CONNECTING THE SWITCH BOX TO THE RELAY AND OMIT STEPS C, D AND E BELOW.**

- FIND A CONVENIENT PLACE TO INSTALL THE SWITCH. DRILL A SMALL PILOT HOLE FIRST AND THEN DRILL IT OUT LARGER WITH A 13/16" DRILL BIT. THE SIDE COVER MAY BE A GOOD LOCATION FOR THE SWITCH.
- THE WIRE HARNESS WITH THREE WIRES (ORANGE, BLUE, AND GREEN) CONNECTS TO THE SWITCH. THE END OF THE HARNESS WITH THE THREE PUSH ON CONNECTORS GOES TO THE TERMINALS OF THE SWITCH AS SHOWN IN THE DIAGRAM.
- FROM THE SWITCH, THE GREEN WIRE CAN BE CONNECTED TO THE NEGATIVE TERMINAL OF THE BATTERY. THE BLUE WIRE CONNECTS TO THE RELAY AS SHOWN IN THE DIAGRAM. THE ORANGE WIRE WILL NEED TO CONNECT TO A KEYED POWER SOURCE. A KEYED POWER SOURCE IS A WIRE THAT HAS POWER ONLY WHEN THE KEY IS IN THE "ACCESSORY" OR "ON" POSITION. WHEN A KEYED POWER SOURCE WIRE IS FOUND, CLAMP THE T-TAP CONNECTOR TO THE WIRE AND THEN CONNECT THE ORANGE WIRE TO THE T-TAP.
- ROUTE THE BARE ENDED WIRES ON EACH LIGHT THROUGH THE LIGHT BAR AND OUT THE MIDDLE HOLE. ATTACH RING TERMINALS TO THE BARE ENDS OF THE WIRES AND THEN PLACE THEM UNDER THE M6-1.0 X 16MM MOUNTING SCREWS UNDER THE LIGHT BAR. TIGHTEN THE SCREWS SECURELY TO INSURE THAT THE LIGHTS HAVE A GOOD GROUND.

- TEST LIGHTS FOR PROPER OPERATION BEFORE REINSTALLING ANY REMOVED SIDE COVERS, SEATS, ETC. SECURE RELAY TO KEEP FROM BOUNCING.

**FIG. 1**

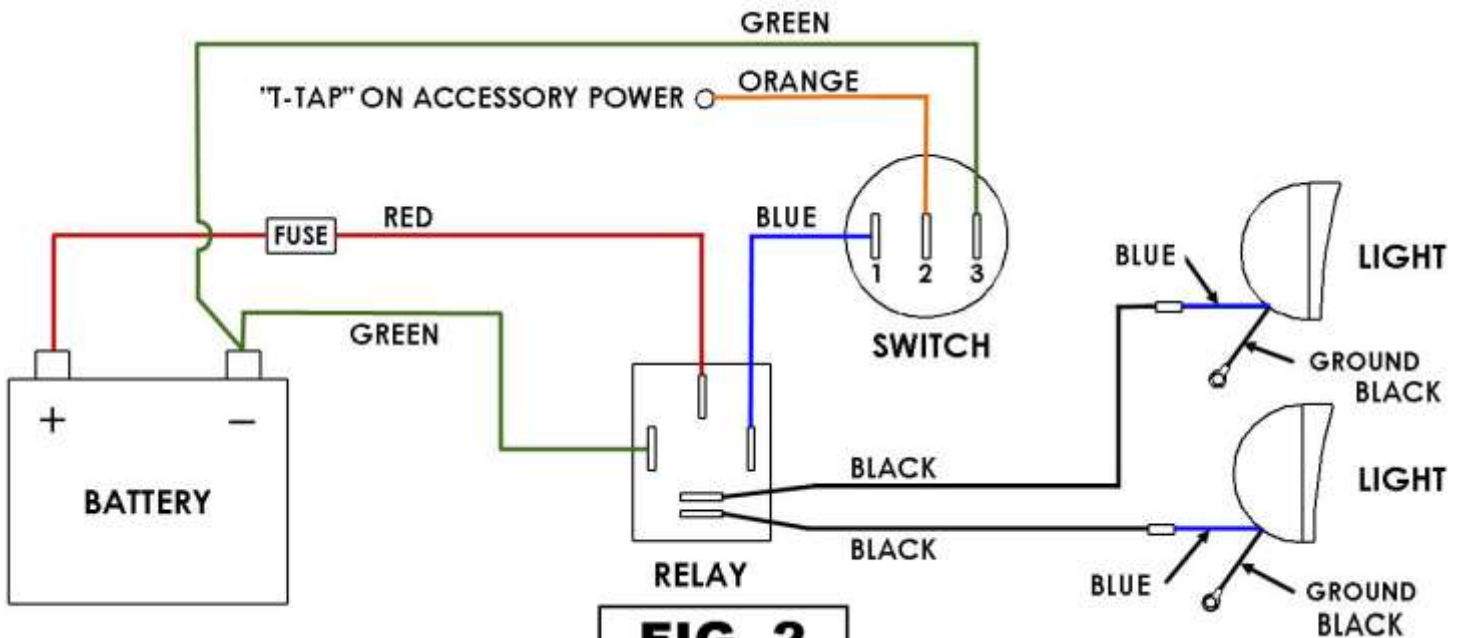
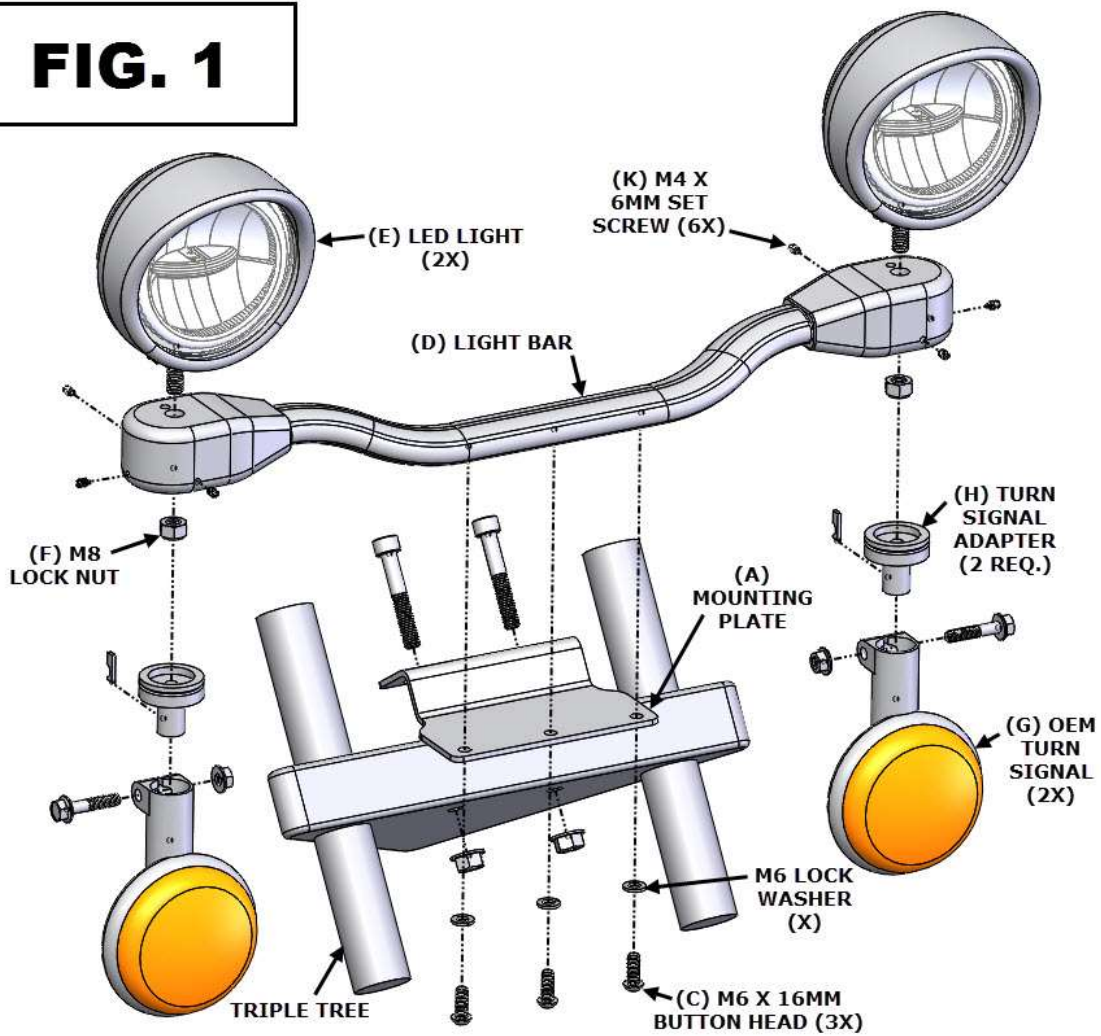

**FIG. 2**